

- during pre-use check it is necessary to inspect all elements of the equipment in respect of any damages, excessive wear, corrosion, abrasion, cutting or incorrect acting, especially take into consideration:
  - in full body harnesses and belts - buckles, adjusting elements, attaching points, webbings, seams, loops;
  - in energy absorbers - attaching loops, webbing, seams, casing, connectors;
  - in textile lanyards or lifelines or guidelines - rope, loops, thimbles, connectors, adjusting element, splices;
  - in steel lanyards or lifelines or guidelines - cable, wires, clips, ferrules, loops, thimbles, connectors, adjusting elements;
  - in retractable fall arresters - cable or webbing, retractor and brake proper acting, casing, energy absorber, connector;
  - in guided type fall arresters - body of the fall arrester, sliding function, locking gear acting, rivets and screws, connector, energy absorber;
  - in connectors - main body, rivets, gate, locking gear acting.
- after every 12 months of utilization, personal protective equipment must be withdrawn from use to carry out periodical detailed inspection. All elements of the equipment must be inspected in respect of any damages, excessive wear, corrosion, abrasion, cutting or incorrect acting (see point above). The periodic inspection must be carried out by a competent person for periodic inspection. The periodic inspection can be carried out also by the manufacturer or his authorized representative. In case of some types of the complex equipment e.g. some types of retractable fall arresters the annual inspection can be carried out only by the manufacturer or his authorized representative.
- regular periodic inspections are essential for equipment maintenance and the safety of the users which depends upon the continued efficiency and durability of the equipment.
- during periodic inspection it is necessary to check the legibility of the equipment marking.
- it is essential for the safety of the user that if the product is re-sold outside the original country of destination the reseller shall provide instructions for use, for maintenance, for periodic examination and for repair in language of the country in which the product is to be used.
- personal protective equipment must be withdrawn from use immediately when any doubt arise about its condition for safe use and not used again until confirmed in writing by equipment manufacturer or his representative after carried out the detailed inspection.
- personal protective equipment must be withdrawn from use immediately and destroyed when it has been used to arrest a fall.
- a full body harness is the only acceptable body holding device that can be used in a fall arrest system.
- in full body harness use only attaching points marked with big letter "A" to attach a fall arrest system. Marking like "A/2" or a half of "A" means the necessity of attaching a fall arrest system to both attaching points together simultaneously. It is strictly forbidden to attach a fall arrest system to the single attaching point marked "A/2" or a half of "A". See drawings below:

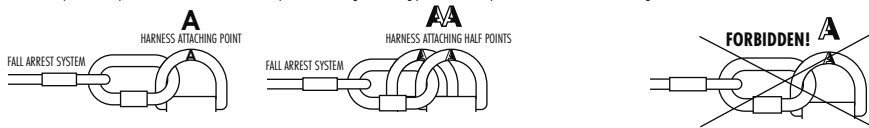

- the anchor device or anchor point for the fall arrest system should always be positioned, and the work carried out in such a way, as to minimise both the potential for falls and potential fall distance. The anchor device/point should be placed above the position of the user. The shape and construction of the anchor device/point shall not be allowed to self-facturing disconnection of the equipment. Minimal static strength of the anchor device/point is 15 kN. It is recommended to use certified and marked structural anchor point complied with EN795.
- it is obligatory to verify the free space required beneath the user at the workplace before each occasion of use of the fall arrest system, so that, in the case of a fall, there will be no collision with the ground or other obstacle in the fall path. The required value of the free space should be taken from instruction manual of used equipment.
- there are many hazards that may affect the performance of the equipment and corresponding safety precautions that have to be observed during equipment utilization, especially:
  - trailing or looping of lanyards or lifelines over sharp edges, any defects like cutting, abrasion, corrosion, climatic exposure, pendulum falls, extremes of temperature, chemical reagents, electrical conductivity.
- personal protective equipment must be transported in the package (e.g.: bag made of moisture-proof textile or foil bag or cases made of steel or plastic) to protect it against damage or moisture.
- the equipment can be cleaned without causing adverse effect on the materials in the manufacture of the equipment. For textile products use mild detergents for delicate fabrics, wash by hand or in a machine and rinse in water. Plastic parts can be cleaned only with water. When the equipment becomes wet, either from being in use or when due cleaning, it shall be allowed to dry naturally, and shall be kept away from direct heat. In metallic products some mechanic parts (spring, pin, hinge, etc.) can be regularly slightly lubricated to ensure better operation.
- Other maintenance and cleaning procedures should be adhered to detailed instructions stated in the manual of the equipment.
- personal protective equipment should be stored loosely packed, in a well-ventilated place, protected from direct light, ultraviolet degradation, damp environment, sharp edges, extreme temperatures and corrosive or aggressive substances.

IT IS THE RESPONSIBILITY OF THE USER ORGANISATION TO PROVIDE THE IDENTITY CARD AND TO FILL IN THE DETAILS REQUIRED.  
 THE IDENTITY CARD SHOULD BE FILLED IN BEFORE THE FIRST USE BY A COMPETENT PERSON, RESPONSIBLE IN THE USER ORGANIZATION FOR PROTECTIVE EQUIPMENT.  
 ANY INFORMATION ABOUT THE EQUIPMENT LIKE PERIODIC INSPECTIONS, REPAIRS, REASONS OF EQUIPMENT'S WITHDRAWN FROM USE SHALL BE NOTED INTO THE IDENTITY CARD BY A COMPETENT PERSON.  
 THE IDENTITY CARD SHOULD BE STORED DURING A WHOLE PERIOD OF EQUIPMENT UTILIZATION. DO NOT USE THE EQUIPMENT WITHOUT THE IDENTITY CARD. ALL RECORDS IN THE IDENTITY CARD CAN BE FILLED IN ONLY BY A COMPETENT PERSON.

## IDENTITY CARD

REF. NUMBER
-------------

SERIAL NUMBER	DATE OF MANUF.
---------------	----------------

USER NAME
-----------

DATE OF PUTTING INTO OPERATION
--------------------------------

DATE OF PURCHASE
------------------

## PERIODIC EXAMINATION AND REPAIR HISTORY

	DATE	REASON FOR ENTRY PERIODIC EXAMINATION OR REPAIR	DEFECTS NOTED, REPAIRS CARRIED OUT AND OTHER RELEVANT INFORMATIONS	NAME AND SIGNATURE OF COMPETENT PERSON	PERIODIC EXAMINATION NEXT DUE DATE
1					
2					
3					
4					

# Instruction Manual

# Lanex

EN 795:1996 - class B

CLASS B **CE 0082** Ref. HSR 100 yy

# HSR 100

horizontal lifeline

EC type examination carried out by CETE APAVE SUDEUROPE, BP 193, 13322 Marseille, France - 0082

The horizontal lifeline HSR 100 is a component of a personal fall arrest equipment. It should be used in situation when the worker has to move often in horizontal plane.

The horizontal lifeline HSR 100 is a temporary anchor device type and is tested and complied with EN 795.

The horizontal lifeline HSR 100 is the protection for a single person only.

## BASIC EQUIPMENT

The horizontal lifeline is made of polyamide kernmantle rope of diameter 10,5 mm.

The line can be ended with loops or loops equipped with thimbles, in configuration showed on the pictures below.

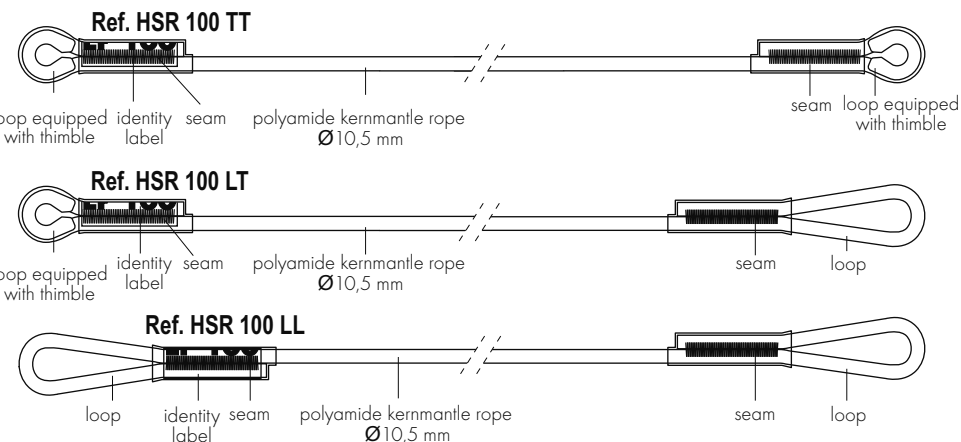

**ATTENTION!** The horizontal lifeline HSR 100 can be equipped only with certified (according to EN 362) snap hooks.

## CONTENT OF THE DEVICE IDENTITY LABEL

material	<b>Horizontal Lifeline</b> POLYAMIDE <b>HSR 100 YY</b>	type of the device
line length	—LENGTH 10 m	reference number of the device*
number of the manufacturing series	Serial number: 0001 Date of manufacture: 08.2002	month/year of the device manufacture
CE marking with identity number of the authorized body for the article 11	<b>CE 0082</b> EN 795:1996 - class B	number/year of the suitable standard and class of the anchorage
caution: read the instruction manual	<b>Lanex</b>	name of the manufacturer or distributor

\*) YY - code of type of line ends  
e.g. YY - LT - loop/loop with thimble

## METHODS OF CONNECTING THE horizontal lifeline TO THE STRUCTURAL ANCHOR POINTS

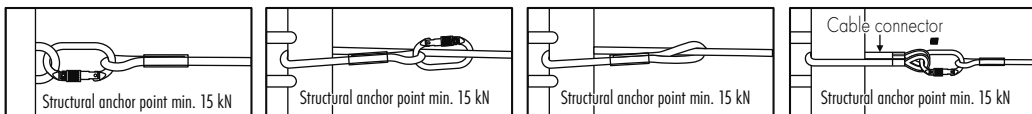

### Attention!

- The shape of the structural anchor point should not let self-acting disconnection of the anchor line.
- The structural anchor point mustn't have sharp edges which could damage the anchor line.
- The structural anchor points have to be situated on the same level and have a minimal static resistance 15 kN. It is recommended to use marked and certified anchor points coplied with EN 795.

## BASIC RULES OF USING THE HORIZONTAL ANCHOR LINE HSR 100

- the horizontal lifeline must only be used by a person previously trained for working at heights.
- the horizontal lifeline is a personal equipment and should be use by one worker.
- before each use, a close visual examination of the snap hooks, rope, splices, must be done in respect of mechanical, chemical and thermal defects. The examination must be carried out by a person who is going to use the horizontal lifeline. In the case of any defect or doubt of correct condition of the horizontal lifeline, do not use it.
- using the horizontal lifeline, in connection with fall arrest system, must be compatible with manual instructions of the fall arrest systems and obligatory standards:
  - EN354 - for the safety lanyards;
  - EN355 - for the energy absorbers;
  - EN361 - for the safety harness;
  - EN362 - for the connectors.
- the energy absorber with lanyard is the only fall arrest subassembly which can be used to connect the worker safety harness to the horizontal lifeline HSR 100.
- it is strictly forbidden to use any retractable type fall aresters or guided type fall arresters instead of the energy absorber with lanyard.
- using the horizontal lifeline requires free distance below the rope level. This distance depends on the anchor line length. See drawing below.

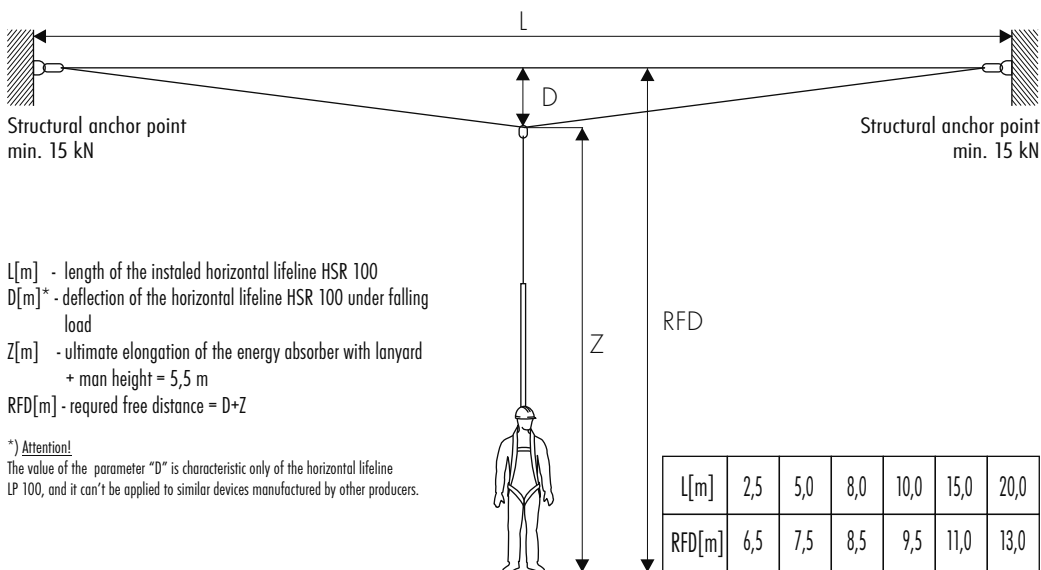

\*) **Attention!**  
The value of the parameter "D" is characteristic only of the horizontal lifeline LP 100, and it can't be applied to similar devices manufactured by other producers.

- the horizontal lifeline HSR 100 should be tensioned (without any sag of rope) between two structural points with hand force.
- if the distance between structural anchor points is too short to tension the horizontal lifeline, it is recommended to shorten the line length by braiding the line around a construction element. If it is necessary make it few times (see drawing below).

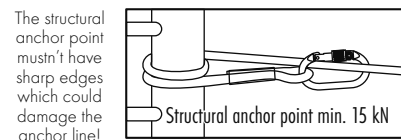

- if there is no possibility to assemble the horizontal lifeline avoiding the sag of rope, we are obliged to add a value of sag to the parameter RFD from the table or employ an adjustable horizontal lifeline e.g. HSL 300.
- when a calculated value of the RFD is higher then free distance at the particular working place we have to:
  - employ an energy absorber with lanyard with shorter entire length;
  - employ a permanent fall arrest system with rigid anchor line.
- horizontal lifeline HSR100 has been tested to the standard EN 795 and is appropriate for single person use with certified energy absorber (according to EN355).
- it is strictly forbidden to use the horizontal lifeline as a vertical anchor line (see drawing below).

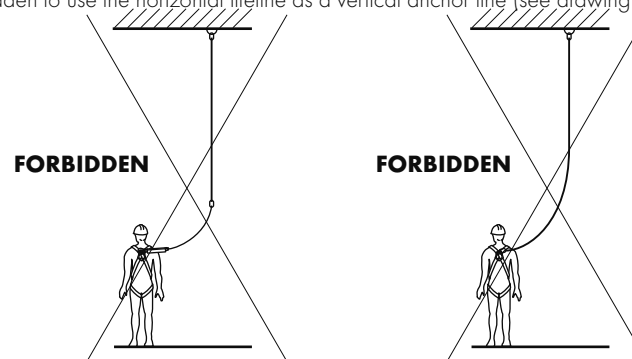

- during using the horizontal lifeline must be protected from a contact with oils, acids, solvents, basics, open fire, hot metal drops and sharp edges. We should avoid using the anchor line in the dust laden and greasy environment.
- it is strictly forbidden to make any modifications to the horizontal lifeline yourself.

### TIME OF USAGE

The horizontal lifeline HSR 100 can be used five years counting from the date of putting the anchor line into operation. After this period the horizontal lifeline HSR 100 must be withdrawn from use and destroyed. The lifeline must be withdrawn from use immediately and destroyed when it have been used to arrest a fall.

## Read carefully before use the equipment

### THE ESSENTIAL PRINCIPLES FOR USERS OF PERSONAL PROTECTIVE EQUIPMENT AGAINST FALLS FROM A HEIGHT

- personal protective equipment shall only be used by a person trained and competent in its safe use.
- personal protective equipment must not be used by a person with medical condition that could affect the safety of the equipment user in normal and emergency use.
- a rescue plan shall be in place to deal with any emergencies that could arise during the work.
- it is forbidden to make any alterations or additions to the equipment without the manufacturer's prior written consent.
- any repair shall only be carried out by equipment manufacturer or his certified representative.
- personal protective equipment shall not be used outside its limitations, or for any purpose other than that for which it is intended.
- personal protective equipment should be a personal issue item.
- before use ensure about the compatibility of items of equipment assembled into a fall arrest system. Periodically check connecting and adjusting of the equipment components to avoid accidental loosening or disconnecting of the components.
- it is forbidden to use combinations of items of equipment in which the safe function of any one item is affected by or interferes with the safe function of another.
- before each use of personal protective equipment it is obligatory to carry out a pre-use check of the equipment, to ensure that it is in a serviceable condition and operates correctly before it is used.

